

CNC File Preferences

The below is a guide of a few things to consider when sending through your files for us to quote/cut, certain requirements are subject to change depending on material, cutting tool, size of cutting objects etc.

File formats we can work with:

- DWG (preferred)
- Rhino 3DM (preferred)

Alternative formats:

- DXF
- Others on application

Layout Preferences:

- Please specify correct sheet size.
- Allow for at least 5mm space around the edge of the sheet and cutting objects, this is subject to change depending on which cutting tool is required and material used.
- At least 10mm space in between all cutting objects, this is subject to change depending on which cutting tool is required and material used.
- Smaller components usually require more space around them for a clean cut.
- Position shapes from smallest to largest from top right down to bottom left of sheet, see pictured.

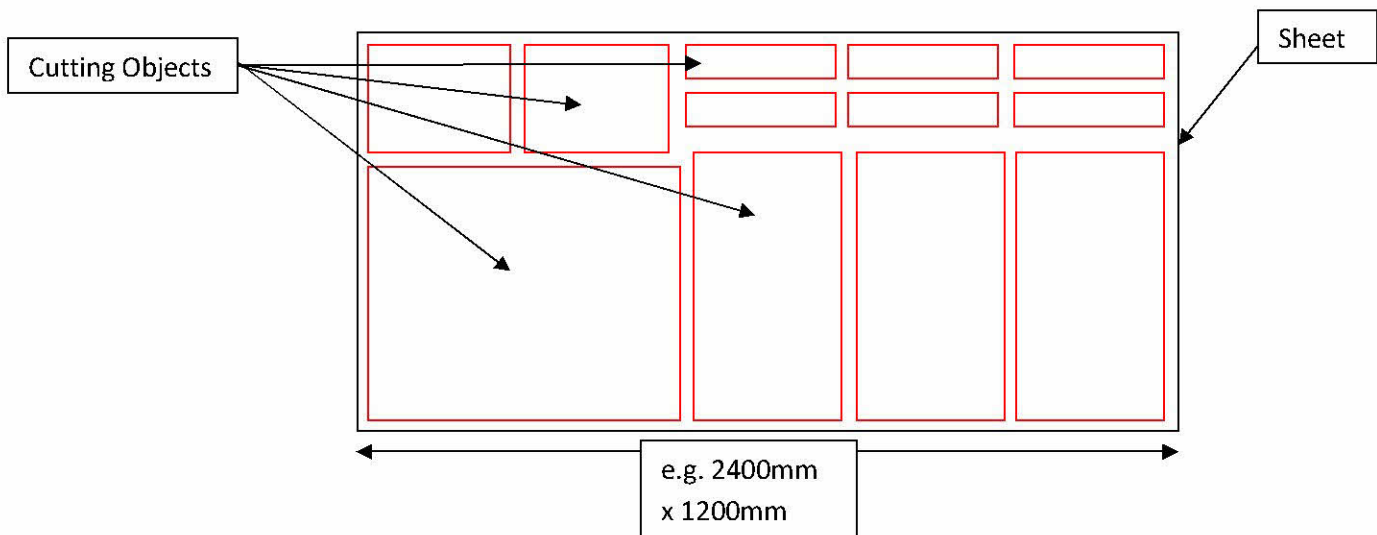

What we can cut:

- Sheets up to 2440mm long x 1800mm wide. Larger in length sheets can be cut upon special application.
- Materials: MDF, plywoods, timber, composite panels, acrylics, melamine, laminated and veneered board, aluminium.